

Dell™ Latitude™ C600/C500 Series

SERVICE MANUAL



www.dell.com
support.dell.com



Dell™ Latitude™ C600/C500 Series

SERVICE MANUAL

www.dell.com
support.dell.com



Notes, Notices, and Cautions



NOTE: A NOTE indicates important information that helps you make better use of your computer.



NOTICE: A NOTICE indicates either potential damage to hardware or loss of data and tells you how to avoid the problem.



CAUTION: A CAUTION indicates a potentially hazardous situation which, if not avoided, may result in minor or moderate injury.

Information in this document is subject to change without notice.

© 2001 Dell Computer Corporation. All rights reserved.

Reproduction in any manner whatsoever without the written permission of Dell Computer Corporation is strictly forbidden.

Trademarks used in this text: *Dell*, the *DELL* logo, and *DellWare* are trademarks of Dell Computer Corporation; *Intel* is a registered trademark of Intel Corporation; *Microsoft* and *Windows* are registered trademarks of Microsoft Corporation.

Other trademarks and trade names may be used in this document to refer to either the entities claiming the marks and names or their products. Dell Computer Corporation disclaims any proprietary interest in trademarks and trade names other than its own.

May 2001 P/N 82EWX Rev. A01

Contents

1 Before You Begin

Preparing to Work Inside the Computer	10
Recommended Tools	11
Screw Identification	12

2 Removing and Replacing Parts

Components	16
Hard Drive	17
Removing the Hard Drive	17
Replacing the Hard Drive	17
Memory Module	18
Removing the Memory Module Cover	18
Removing the Memory Modules	19
Replacing the Memory Modules	20
Mini-PCI Card Assembly	20
Removing the Mini-PCI Card Assembly	22
Replacing the Mini-PCI Card Assembly	22
Keyboard Assembly	23
Removing the Keyboard Assembly	23
Replacing the Keyboard Assembly	25
Removing the Display Assembly	26
Removing the 14.1-Inch Display Assembly Bezel	30
Removing the 14.1-Inch Display Panel	30

Replacing the 14.1-Inch Display Panel	31
Removing the Display-Feed Flex Cable (14.1-Inch Display Panel)	32
Removing the 12.1-Inch Display Assembly Bezel	34
Removing the 12.1-Inch Display Panel	34
Replacing the Display-Assembly Top Cover	35
Replacing the 12.1-Inch Display Panel	35
Removing the Display-Feed Flex Cable (12.1-Inch Display Panel)	36
Display Assembly Latch	37
Removing the Display Assembly Latch	37
Hinge Covers	39
Removing the Hinge Covers	39
Replacing the Hinge Covers	40
Palmrest Assembly	41
Removing the Palmrest Assembly	41
Microprocessor Thermal Cooling Assembly	44
Removing the Microprocessor Thermal Cooling Assembly	44
Hybrid Cooling Fan	45
Removing the Hybrid Cooling Fan	46
Microprocessor Module	47
Removing the Microprocessor Module	47
Replacing the Microprocessor Module	48
Reserve Battery	49
Removing the Reserve Battery	49
Replacing the Reserve Battery	50
Speaker Assemblies	50
Removing the Speaker Assemblies	51
Replacing the Speaker Assembly	53
System Board Assembly	53
Removing the System Board	54
Replacing the System Board	56

Battery and Modular Bay Latch Assemblies 57
 Removing the Battery and Modular Bay Latch Assemblies 57

Index 59

SECTION 1

Before You Begin

- Preparing to Work Inside the Computer
- Recommended Tools
- Screw Identification

Preparing to Work Inside the Computer

- ➡ **NOTICE:** Only a certified service technician should perform repairs on your system. Damage due to servicing that is not authorized by Dell is not covered by your warranty.
- ➡ **NOTICE:** To avoid damaging the computer, perform the following steps before you begin working inside the computer.
 - 1 **Make sure that the work surface is clean to prevent scratching the computer cover.**
 - 2 **Save any work in progress and close all open application programs.**
 - 3 **Turn off the computer and all attached devices.**
 - ✍ **NOTE:** Make sure the computer is turned off and not in suspend-to-disk or hibernate mode. If you cannot shut down the computer using the computer's operating system, press and hold the power button for 4 seconds.
 - 4 **Make sure the computer is undocked.**
 - 5 **Disconnect the computer from the electrical outlet.**
 - 6 **To avoid possible damage to the system board, wait 10 to 20 seconds and then disconnect any attached devices.**
 - 7 **Disconnect all other external cables from the computer.**
 - 8 **Remove any installed PC Cards or plastic blanks from the PC Card slot.**
 - 9 **Close the display and turn the computer upside down on a flat work surface.**
- ➡ **NOTICE:** To avoid damaging the system board, you must remove the main battery and secondary battery (if present) before you service the computer.
- 10 **Remove the primary battery from the battery bay and the secondary battery from the modular bay, if a secondary battery is in use.**
- 11 **Remove any installed device in the modular bay.**
- 12 **To dissipate any static electricity while you work, use a wrist grounding strap or periodically touch an unpainted metal surface.**

- 13 Handle components and cards with care. Do not touch the components or contacts on a card. Hold a card by its edges or by its metal mounting bracket. Hold a component such as a microprocessor by its edges, not by its pins.

Recommended Tools

The procedures in this manual require the following tools:

- #1 magnetized Phillips screwdriver
- Small flat-blade screwdriver
- Small plastic scribe
- Microprocessor extractor
- Flash BIOS update program diskette or CD (required only when upgrading the microprocessor or replacing the reserve battery)

System Orientation

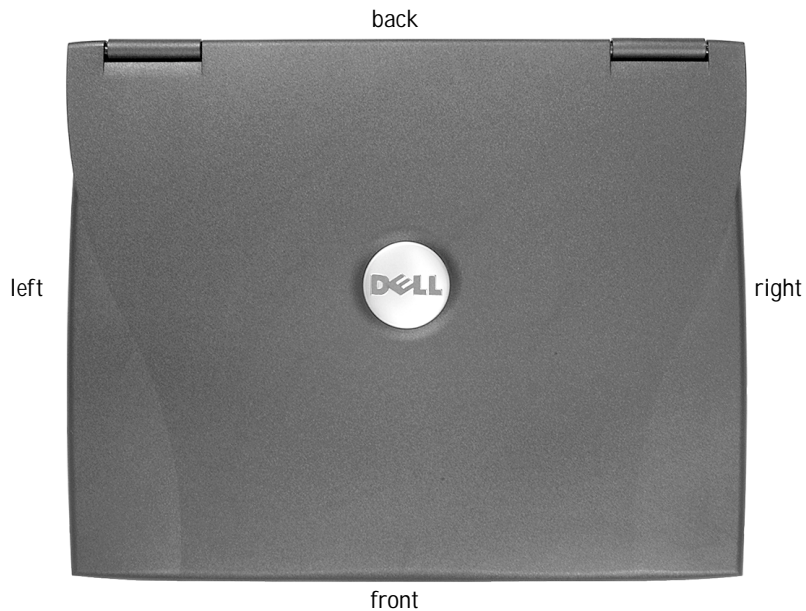

Screw Identification

When you are removing and replacing components, photocopy the placemat as a tool to lay out and keep track of the component screws. The placemat provides the number of screws and the sizes.

Screw Identification

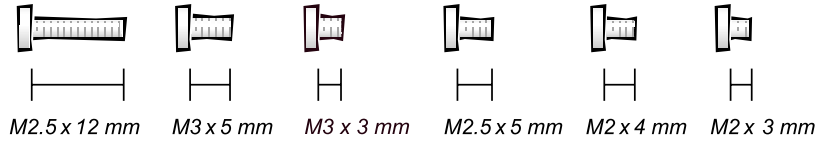

➔ NOTICE: When reinstalling a screw, you must use a screw of the correct diameter and length. Make sure that the screw is properly aligned with its corresponding hole, and avoid overtightening.

Screw Placement

Hard Drive Door Security:

(1 each)



M3 x 5 mm

Keyboard to Bottom Case Assembly:

(5 each)

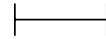

M2.5 x 12 mm

Screw Placement

**Display Assembly
Bezel:**

(6 each)



M2.5 x 5 mm

Rubber Screw Covers (6 each)

**Display Assembly
Hinge Bracket to
Bottom Case
Assembly:**

(5 each)



M2.5 x 5 mm

**Display Assembly
and Flex Cable
Retention Bracket to
Top Cover:**

(5 each)



M2 x 4 mm

**Display Assembly
EMI Shield Bracket:**

(2 each)



M2 x 3 mm

**Palmrest to Bottom
Case Assembly:**

(5 each)

(3 each)



M2 x 3 mm

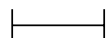
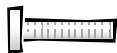

M2.5 x 12 mm

Hybrid Cooling Fan:

(2 each)

(1 each)



M2.5 x 5 mm



M2 x 3 mm

Screw Placement

System Board to Bottom Case Assembly:

(10 each)



M2.5 x 5 mm

Display Panel to Support Bracket:

(12.1-inch display panel only)

(4 each)



M3 x 3 mm

Display Assembly Latch:

(2 each for 14.1-inch XGA display panels)



M2.5 x 5 mm

SECTION 2

Removing and Replacing Parts

- Components
- Hard Drive
- Memory Module
- Mini-PCI Card Assembly
- Keyboard Assembly
- Removing the Display Assembly
- Display Assembly Latch
- Hinge Covers
- Palmrest Assembly
- Microprocessor Thermal Cooling Assembly
- Hybrid Cooling Fan
- Microprocessor Module
- Reserve Battery
- Speaker Assemblies
- System Board Assembly
- Battery and Modular Bay Latch Assemblies

Components

Exploded View

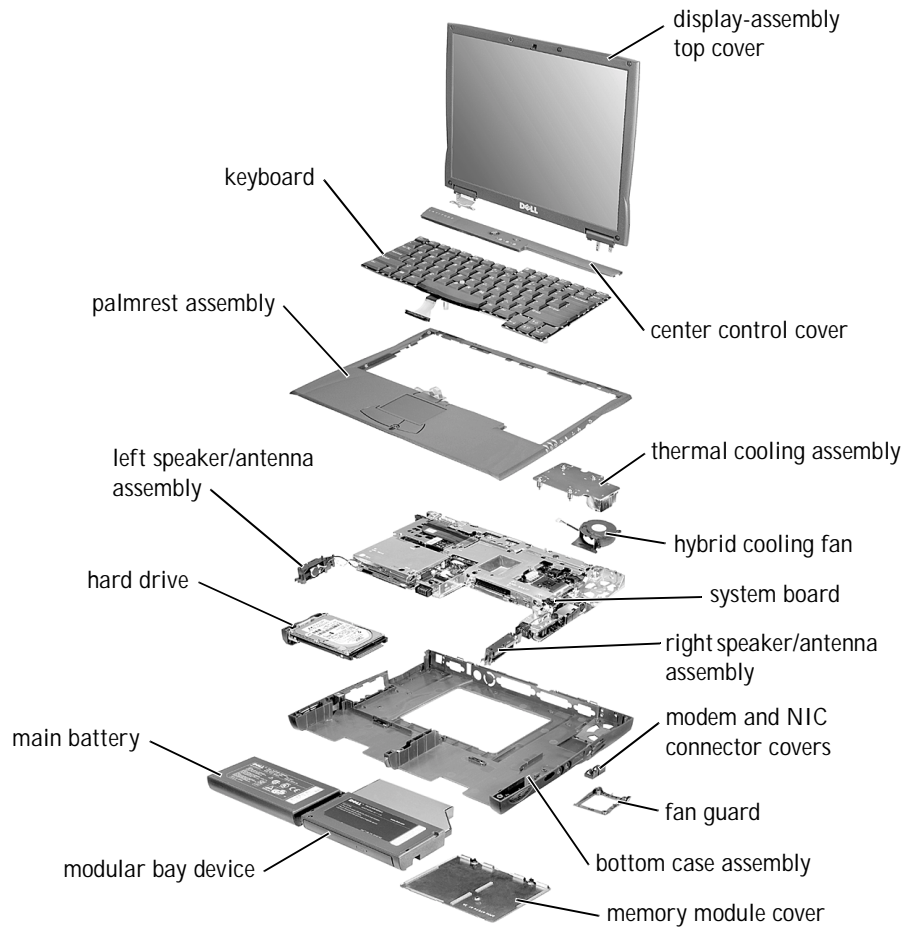

➡ **NOTICE:** Only a certified service technician should perform repairs on your system. Damage due to servicing that is not authorized by Dell is not covered by your warranty.

➡ **NOTICE:** Unless otherwise noted, each procedure in this manual assumes that a part can be replaced by performing the removal procedure in reverse order.

Hard Drive

- ➔ **NOTICE:** The hard drive is very sensitive to shock. Handle the assembly by its edges (do not squeeze the top of the hard drive case), and avoid dropping it.

Hard Drive

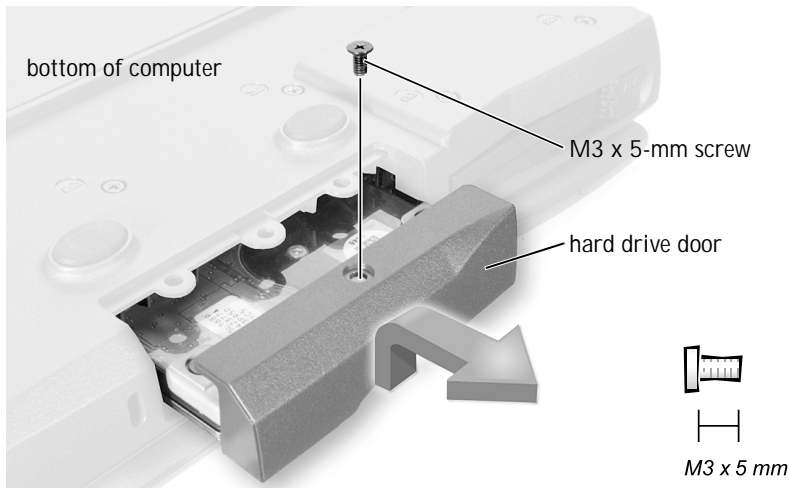

Removing the Hard Drive

- ➔ **NOTICE:** Disconnect the computer and any attached devices from electrical outlets, and remove any installed batteries.
 - ➔ **NOTICE:** To avoid ESD, ground yourself by using a wrist grounding strap or by touching an unpainted metal surface on the computer.
 - ➔ **NOTICE:** Read "Preparing to Work Inside the Computer" before performing the following procedure.
- 1 Remove the M3 x 5-mm screw from the hard drive door.
 - 2 Slide the drive door up until the drive assembly tabs disengage from the door slots in the bottom case assembly.
 - 3 Pull the hard drive straight out of the bottom case assembly.

Replacing the Hard Drive

- 1 Gently push the hard drive into the drive bay until the drive door is flush with the computer case.

- 2 Push down on the drive door until it snaps into place.
- 3 Replace the M3 x 5-mm screw in the hard drive door.

Memory Module

Memory Module Cover

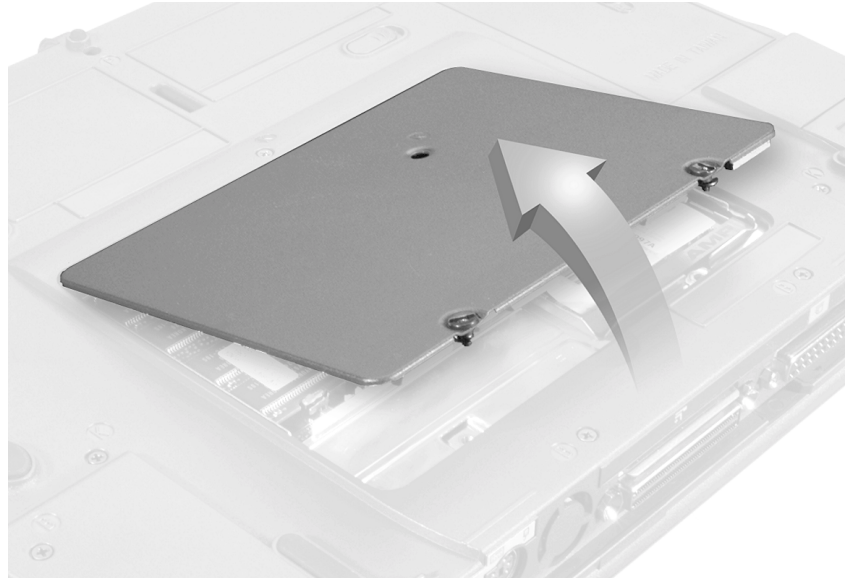

Removing the Memory Module Cover

- ➡ NOTICE: Disconnect the computer and any attached devices from electrical outlets, and remove any installed batteries.
- ➡ NOTICE: To avoid ESD, ground yourself by using a wrist grounding strap or by touching an unpainted metal surface on the computer.
- ➡ NOTICE: Read "Preparing to Work Inside the Computer" before performing the following procedure.

- 1 Remove the memory module cover:
 - a Use a coin or flat-blade screwdriver to release the two captive screws that secure the memory module cover.
 - b Place your finger under the cover at the indentation and lift and slide the cover open.

- NOTE: The screw labeled with the "circle K" in the middle of the memory module cover secures the keyboard assembly and does not secure the memory module cover.

Memory Modules

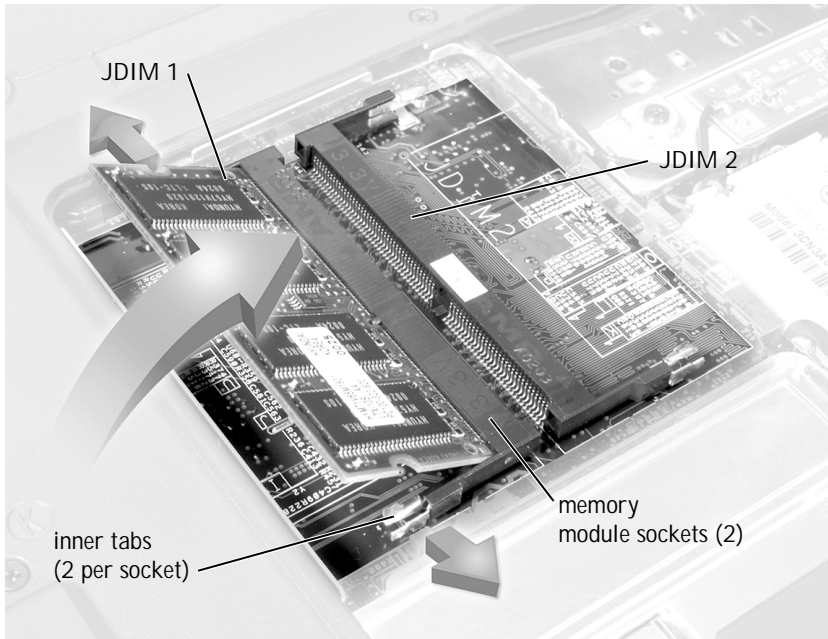

Removing the Memory Modules

- NOTICE: Disconnect the computer and any attached devices from electrical outlets, and remove any installed batteries.
- NOTICE: To avoid ESD, ground yourself by using a wrist grounding strap or by touching an unpainted metal surface on the computer.

 **NOTICE:** Read "Preparing to Work Inside the Computer" before performing the following procedure.

- 1 Remove the memory module cover.
- 2 To release a memory module from its socket, spread apart the inner tabs of the memory module socket just far enough for the memory module to disengage from the socket. The module should pop up slightly.
- 3 Lift the memory module out of its socket.

Replacing the Memory Modules

- 1 If you only have one memory module, install it in the socket labeled "JDIM1." Install a second memory module in the socket labeled "JDIM2."

 **NOTE:** Memory modules are keyed, or designed to fit into their sockets, in only one direction.

 **NOTICE:** The memory module must be inserted at a 45-degree angle to avoid damaging the connector.

- 2 Align the memory module's edge connector with the slot in the center of the memory module socket. With the module at a 45-degree angle, press the memory module's edge connector firmly into the memory module socket.
- 3 Pivot the memory module down until it clicks into place. If you do not hear a click, remove the memory module and reinstall it.
- 4 Insert the tabs on the memory module cover into the bottom case assembly. Rotate the memory module cover down and tighten the two captive screws.

Mini-PCI Card Assembly

You must remove the optional mini-PCI card assembly before the system board assembly can be removed. A mini-PCI card assembly may consist of a modem, a NIC, a modem and NIC combination, or a wireless NIC. A modem, NIC, or modem and NIC combination must be connected to the wiring harness as appropriate; a wireless NIC must be connected to the system's internal antenna.

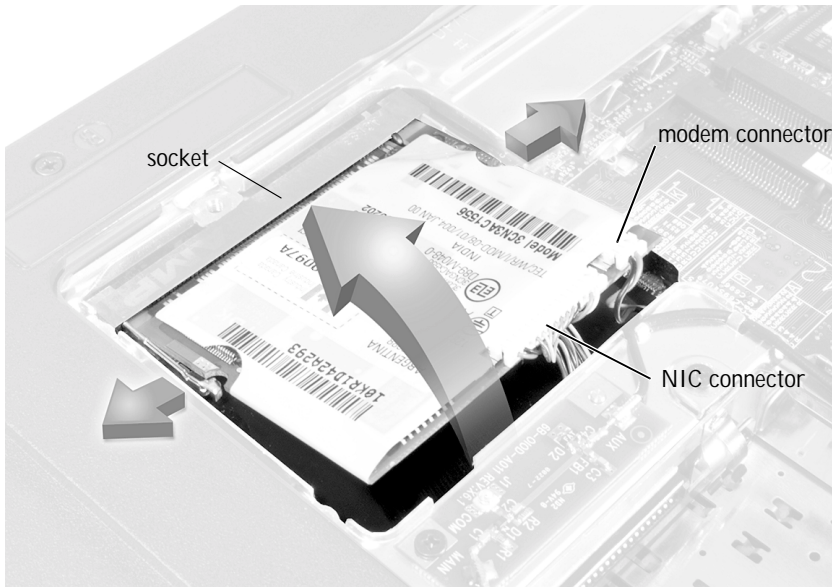

Mini-PCI Card Assembly Using Interface Cables



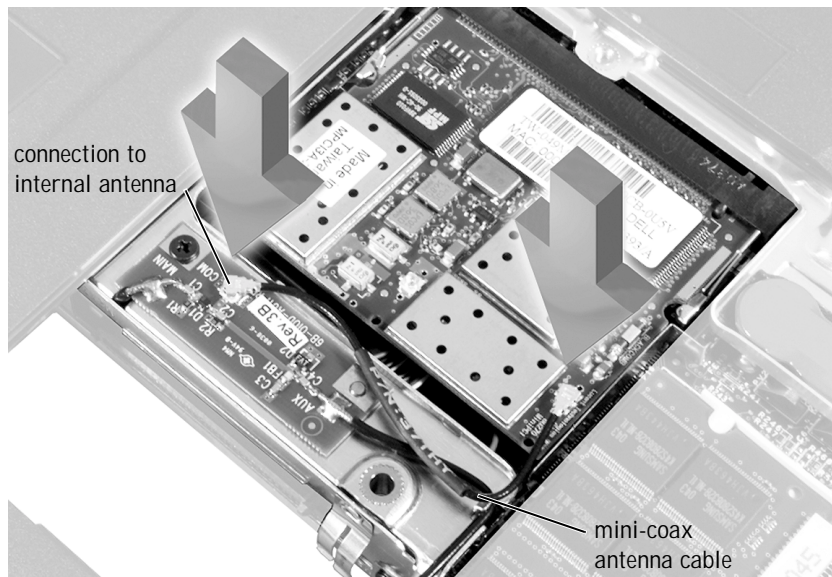



Mini PCI Wireless NIC Assembly Using Antenna Cable



Removing the Mini-PCI Card Assembly

-  **NOTICE:** Disconnect the computer and any attached devices from electrical outlets, and remove any installed batteries.
-  **NOTICE:** To avoid ESD, ground yourself by using a wrist grounding strap or by touching an unpainted metal surface on the computer.
-  **NOTICE:** Read "Preparing to Work Inside the Computer" before performing the following procedure.
 - 1 **Remove the memory module cover.**
 - 2 **To release the mini-PCI card assembly from its socket, spread apart the metal securing tabs until the assembly pops up slightly.**
 - 3 **Lift the mini-PCI card assembly out of its socket and disconnect any attached cables.**

Replacing the Mini-PCI Card Assembly

-  **NOTICE:** The mini-PCI card must be inserted at a 45-degree angle to avoid damaging the connector.
-  **NOTICE:** The mini-PCI card is keyed, or designed to fit into its socket, in only one direction. Do not force the connection.
 - 1 **Align the mini-PCI card with the socket at a 45-degree angle, and press the mini-PCI card firmly into the socket.**
 - 2 **Depending on the type of mini-PCI card you are installing, either connect the interface cables to the mini-PCI card, or connect the mini-coax antenna cable from the mini-PCI card to the internal antenna.**
 - 3 **Lower the mini-PCI card until it snaps into the metal securing tabs.**
 -  **NOTE:** If you are installing a wireless NIC, fold and tuck the unused interface cables into the slot so they do not interfere with the cover.
 -  **NOTE:** A modem-only mini-PCI card has one connector; place the unused NIC connector under the mini-PCI card.
 - 4 **Replace the memory module cover.**

Keyboard Assembly

Removing the Keyboard Screws

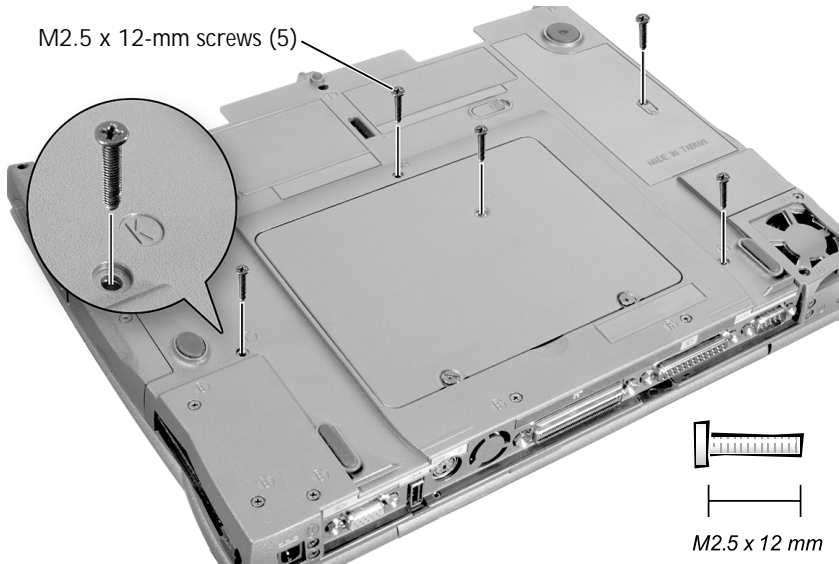

Removing the Keyboard Assembly

- ➔ NOTICE: Disconnect the computer and any attached devices from electrical outlets, and remove any installed batteries.
 - ➔ NOTICE: To avoid ESD, ground yourself by using a wrist grounding strap or by touching an unpainted metal surface on the computer.
 - ➔ NOTICE: Read "Preparing to Work Inside the Computer" before performing the following procedure.
- 1 Remove the hard drive.
 - 2 Turn the computer over, and remove the five M2.5 x 12-mm screws from the holes labeled "circle K."
 - 3 Turn the computer over and open the display.
- ➔ NOTICE: The key caps on the keyboard are fragile, easily dislodged, and time-consuming to replace. Be careful when removing and handling the keyboard.

- 4 To release the keyboard from the palmrest assembly, use a small, flat-blade screwdriver or plastic scribe to pull up on the scalloped edge of the blank key on the keyboard.

 **NOTE:** Removing the center control cover provides more room to free the keyboard.

Keyboard

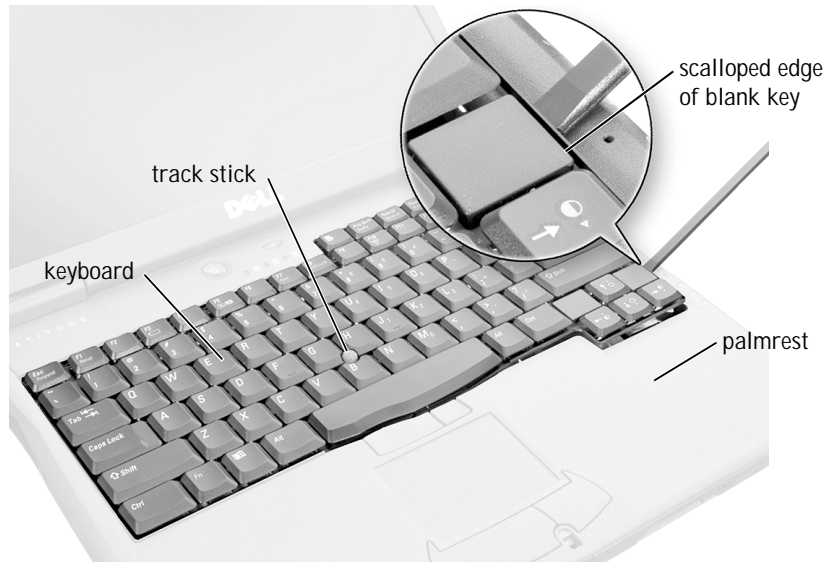

- 5 Lift the keyboard straight up until it clears the keyboard boss support in the bottom case assembly.
- 6 Rotate the keyboard forward toward the front of the computer.
- 7 Rest the key face of the keyboard on the palmrest.

Keyboard Connector

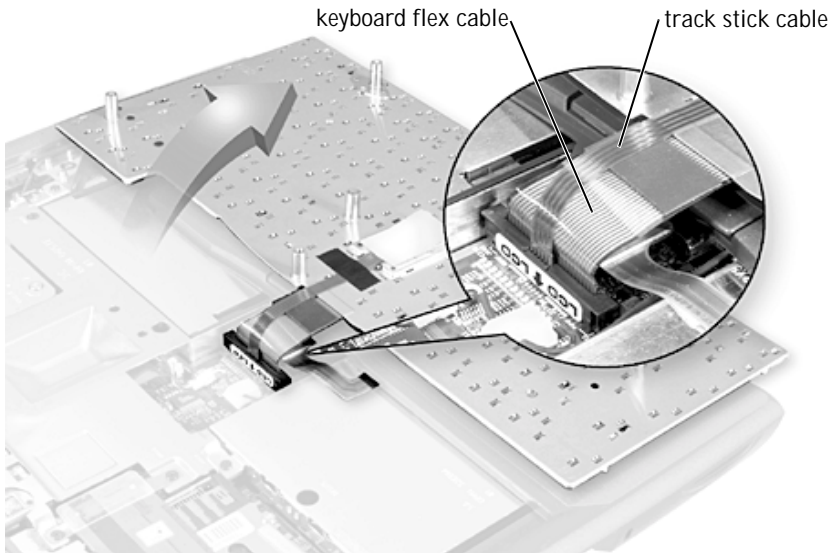

- 8 Disconnect the keyboard flex cable from the interface connector on the system board assembly by pulling up on the connector.

➔ NOTICE: Do not pull on the keyboard flex cable.

- 9 Remove the keyboard assembly from the bottom case assembly.

Replacing the Keyboard Assembly

- 1 Place the keyboard on the palmrest at the front of the computer with the keys face down and the connector toward the back of the computer.

➔ NOTICE: To avoid damage to the connector pins, press the keyboard connector evenly into the interface connector, and do not reverse the keyboard connector.

- 2 Connect the keyboard flex cable to the interface connector on the system board assembly.
- 3 Carefully turn the keyboard over and fit the keyboard into place.

- ➡ NOTICE: Position the keyboard flex cable so it is not pinched when you replace the keyboard in the bottom case assembly.
- 4 Check that the keyboard is correctly installed. The keys should be flush with the left and right surfaces of the palmrest.
- 5 Reinstall the five M2.5 x 12-mm screws in the holes labeled "circle K."

Removing the Display Assembly

- ➡ NOTICE: You must remove the display assembly before you remove the palmrest assembly; the display assembly hinges pass through the back of the palmrest assembly.
- ✍ NOTE: Always remove and replace the display panel as a complete assembly.
- ➡ NOTICE: Disconnect the computer and any attached devices from electrical outlets, and remove any installed batteries.
- ➡ NOTICE: To avoid ESD, ground yourself by using a wrist grounding strap or by touching an unpainted metal surface on the computer.
- ➡ NOTICE: Read "Preparing to Work Inside the Computer" before performing the following procedure.

Display Assembly

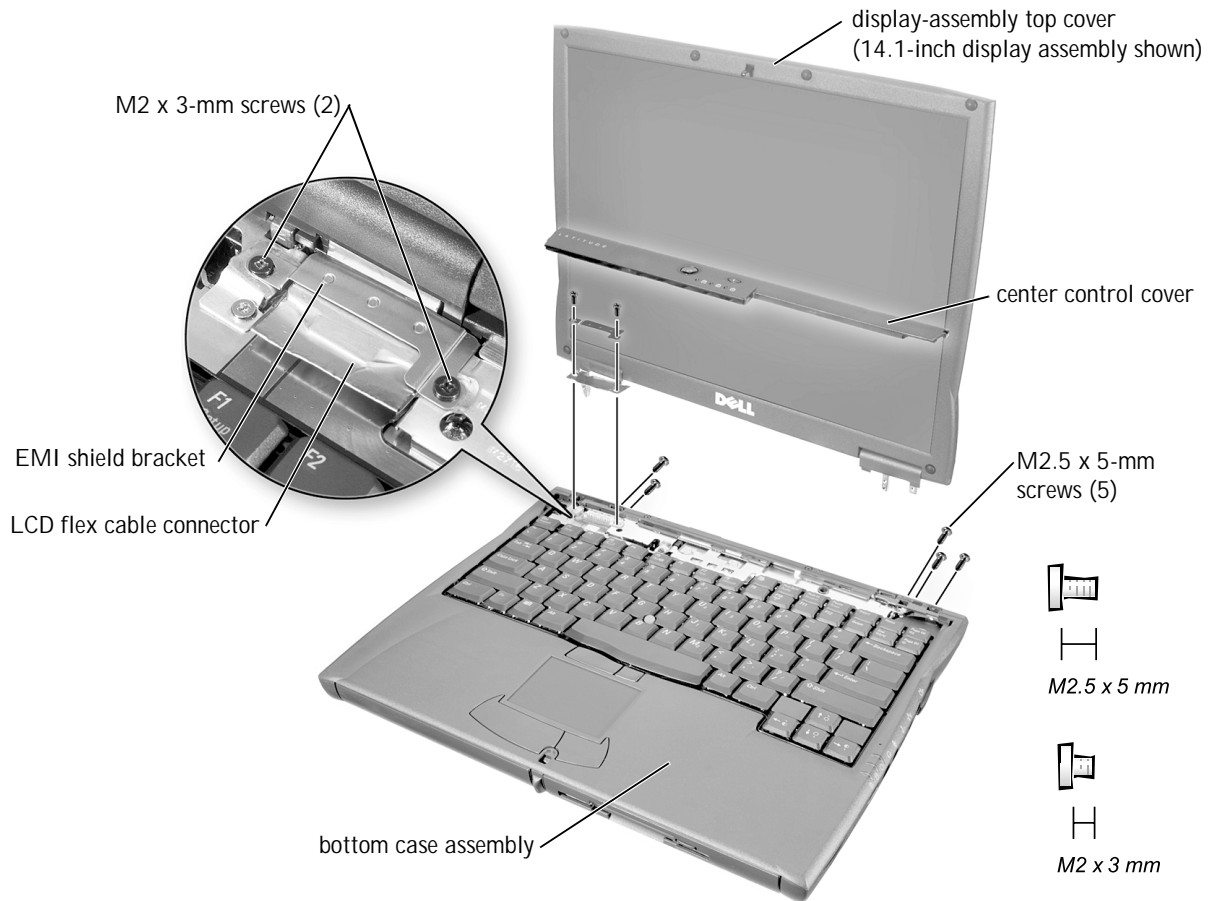

- 1 Remove the hard drive.
- 2 Remove the center control cover.
 - a Use a scribe to lift the right edge of the center control cover and pry it loose from the bottom case assembly.
 - b Lift the center control cover up and away from the bottom case assembly.
- 3 Close the display.

- 4 From the back of the computer, remove the five M2.5 x 5-mm screws labeled with the "circle D." There are two screws on the right hinge and three screws on the left hinge.
 - 5 Open the display assembly approximately 180 degrees and support the display assembly so it does not open past this position.
 - 6 Remove the two M2 x 3-mm screws that secure the EMI shield bracket to the system board assembly.
 - 7 Remove the flex cable EMI shield retention bracket that covers the display-feed flex cable connector on the system board.
 - 8 Pull straight up on the display-feed flex cable connector to disconnect the connector from the system board (see "Display Assembly").
 - 9 Lift the display assembly from the bottom case assembly.
- ➡ **NOTICE:** When reconnecting the display-feed flex cable connector to the system board, push down on the top left and right ends of the connector (see "Reconnecting the Display-Feed Flex Cable Connector"). Pressing on the center of the connector may damage resistors and compromise EMI protection in the system.



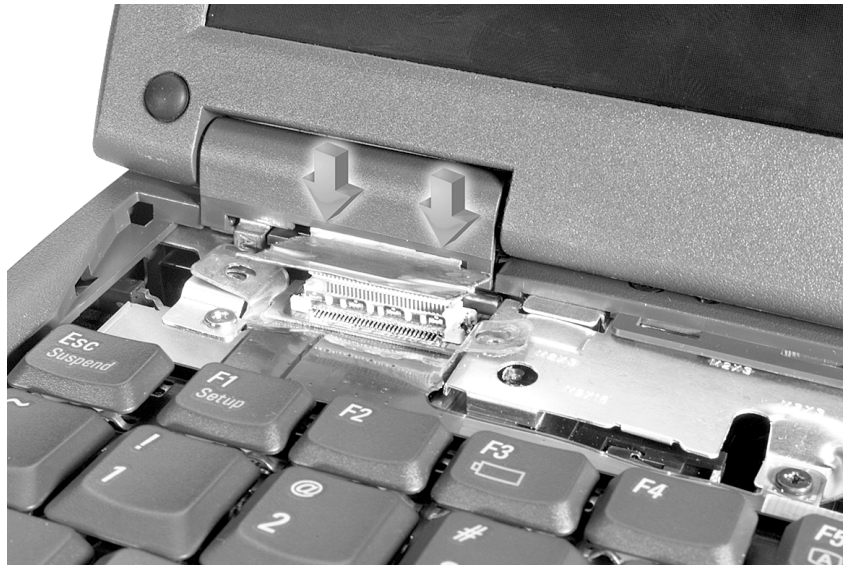

Reconnecting the Display-Feed Flex Cable Connector

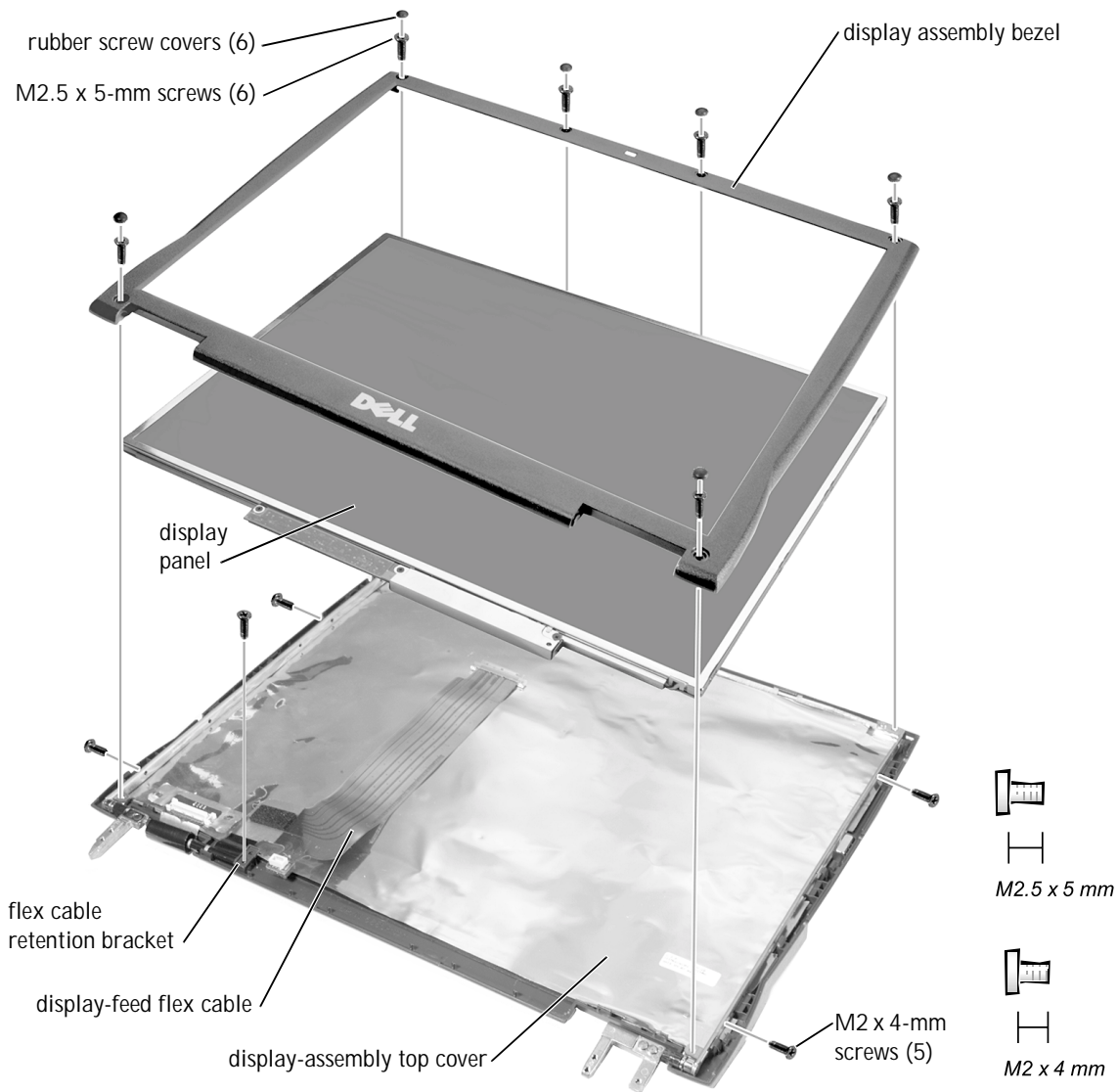



14.1-Inch Display Assembly Bezel and Panel



Removing the 14.1-Inch Display Assembly Bezel

-  **NOTICE:** Disconnect the computer and any attached devices from electrical outlets, and remove any installed batteries.
-  **NOTICE:** To avoid ESD, ground yourself by using a wrist grounding strap or by touching an unpainted metal surface on the computer.
-  **NOTICE:** Read "Preparing to Work Inside the Computer" before performing the following procedure.
 - 1 **Remove the hard drive.**
 - 2 **Remove the display assembly.**
 - 3 **Use the scribe to pry the six rubber screw covers out of the screw holes located on the bezel on the front of the display assembly.**
 - 4 **Remove the six M2.5 x 5-mm screws located on the bezel on the front of the display assembly.**
-  **NOTICE:** To avoid damage to the bezel, do not bend the bezel while separating it from the display-assembly top cover.
 - 5 **Use a plastic scribe to carefully separate the bezel from the display-assembly top cover.**

Removing the 14.1-Inch Display Panel

-  **NOTICE:** Disconnect the computer and any attached devices from electrical outlets, and remove any installed batteries.
 -  **NOTICE:** To avoid ESD, ground yourself by using a wrist grounding strap or by touching an unpainted metal surface on the computer.
 - 1 **Remove the hard drive.**
 - 2 **Remove the display assembly.**
 - 3 **Remove the display assembly bezel.**
 - 4 **Remove the hinge covers.**
 - 5 **Remove the two M2 x 4-mm screws on the left side of the display panel and the two M2 x 4-mm screws on the right side of the display panel.**
-  **NOTE:** If you have a Hitachi display panel, remove the two M2 x 4-mm screws from the center of the left side of the display panel.

- 6 Remove the M2 x 4-mm screw that secures the display-feed flex cable to the display assembly through the black plastic flex cable retention bracket (see "14.1-Inch Display Assembly Bezel and Panel").
- 7 Disconnect the bottom flex cable connector from the display-assembly top cover and inverter connector by pulling straight up on the attached pull tab.
- 8 Lift and rotate the top of the display panel out of the display-assembly top cover.

Replacing the 14.1-Inch Display Panel

- 1 Place the bottom edge of the display panel in the bottom of the display-assembly top cover and elevate the top of the panel with your hand.
- 2 Place the display panel in the display-assembly top cover.
- 3 Reinstall the five M2 x 4-mm screws that secure the display panel to the display-assembly top cover.

Removing the Display-Feed Flex Cable (14.1-Inch Display Panel)

Display-Feed Flex Cable

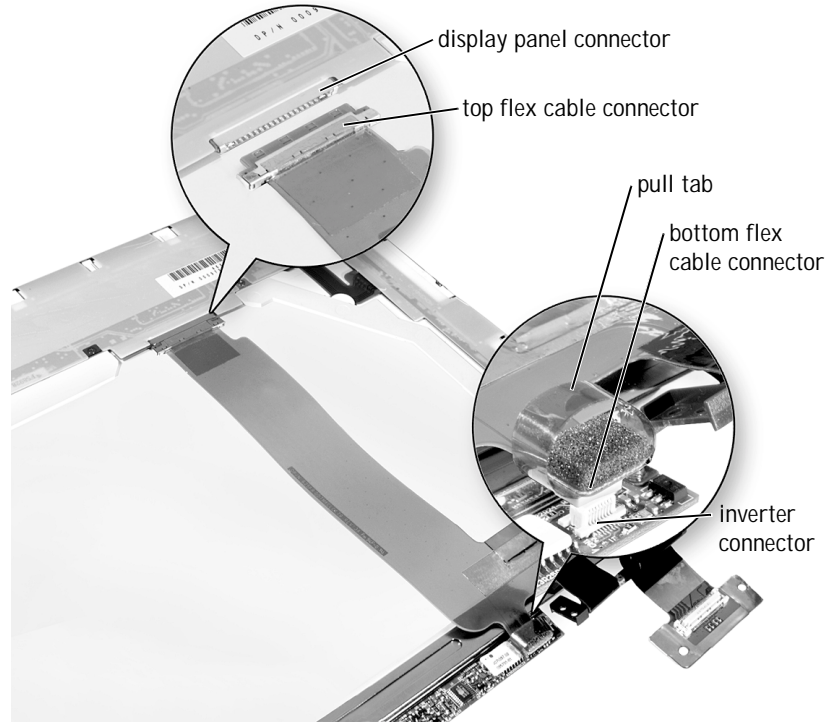

- ➡ **NOTICE:** Disconnect the computer and any attached devices from electrical outlets, and remove any installed batteries.
 - ➡ **NOTICE:** To avoid ESD, ground yourself by using a wrist grounding strap or by touching an unpainted metal surface on the computer.
 - ➡ **NOTICE:** Read "Preparing to Work Inside the Computer" before performing the following procedure.
- 1 **Remove the hard drive.**
 - 2 **Remove the display assembly.**
 - 3 **Remove the display assembly bezel.**
 - 4 **Remove the tape that covers the display panel connector.**
 - 5 **Pull the top flex cable connector down and away to remove it from the display panel connector.**

12.1-Inch Display Assembly Bezel and Panel

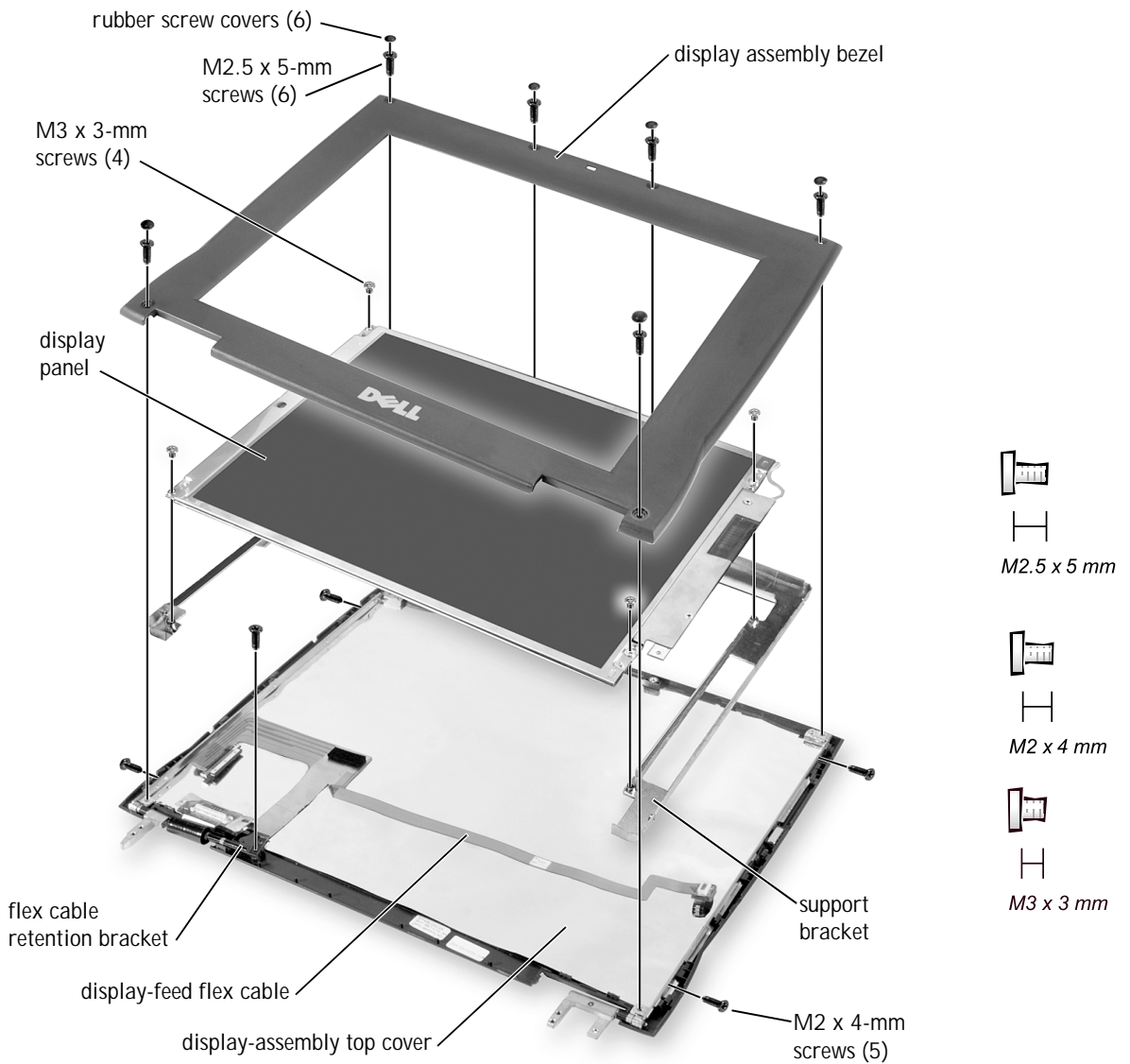

Removing the 12.1-Inch Display Assembly Bezel

- ➡ NOTICE: Disconnect the computer and any attached devices from electrical outlets, and remove any installed batteries.
- ➡ NOTICE: To avoid ESD, ground yourself by using a wrist grounding strap or by touching an unpainted metal surface on the computer.
- ➡ NOTICE: Read "Preparing to Work Inside the Computer" before performing the following procedure.
 - 1 Remove the hard drive.
 - 2 Remove the display assembly.
 - 3 Use the scribe to pry the six rubber screw covers out of the screw holes located on the bezel on the front of the display assembly.
 - 4 Remove the six M2.5 x 5-mm screws located on the bezel on the front of the display assembly.
- ➡ NOTICE: To avoid damage to the bezel, do not bend the bezel while separating it from the display-assembly top cover.
 - 5 Use a plastic scribe to carefully separate the bezel from the display-assembly top cover.

Removing the 12.1-Inch Display Panel

- ➡ NOTICE: Disconnect the computer and any attached devices from electrical outlets, and remove any installed batteries.
- ➡ NOTICE: To avoid ESD, ground yourself by using a wrist grounding strap or by touching an unpainted metal surface on the computer.
 - 1 Remove the hard drive.
 - 2 Remove the display assembly.
 - 3 Remove the display assembly bezel.
 - 4 Remove the hinge covers.
 - 5 Remove the four M3 x 3-mm screws on the front of the display panel that secure the display panel to the support bracket.
 - 6 Remove the M2 x 4-mm screw that secures the display-feed flex cable to the display assembly through the black plastic flex cable retention bracket (see "12.1-Inch Display Assembly Bezel and Panel").

- 7 Lift up the right side of the display panel, and pull the panel out of the display-assembly top cover at an angle.

Replacing the Display-Assembly Top Cover

If you are replacing the display-assembly top cover, remove the support bracket.

- 1 Remove the two M2 x 4-mm screws on the left side of the display-assembly top cover and the two M2 x 4-mm screws on the right side of the display-assembly top cover.
- 2 Lift the support bracket out of the display-assembly top cover.

Replacing the 12.1-Inch Display Panel

- 1 Place the left edge of the display panel against the left side of the support bracket in the display-assembly top cover, and elevate the right side of the panel with your hand.
- 2 Lay the display panel into the display-assembly top cover.
- 3 Reinstall the four M3 x 3-mm screws that secure the display panel to the support bracket.

Removing the Display-Feed Flex Cable (12.1-Inch Display Panel)

Display-Feed Flex Cable

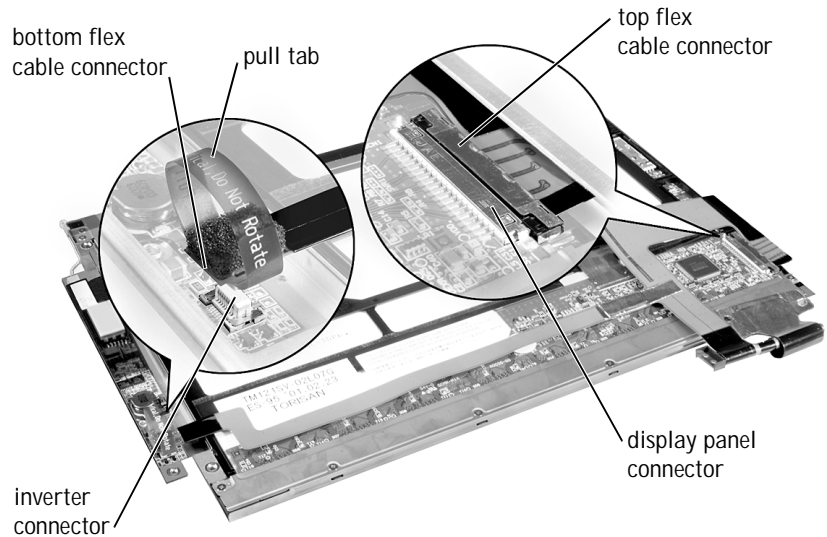

- ➡ **NOTICE:** Disconnect the computer and any attached devices from electrical outlets, and remove any installed batteries.
 - ➡ **NOTICE:** To avoid ESD, ground yourself by using a wrist grounding strap or by touching an unpainted metal surface on the computer.
 - ➡ **NOTICE:** Read "Preparing to Work Inside the Computer" before performing the following procedure.
- 1 **Remove the hard drive.**
 - 2 **Remove the display assembly.**
 - 3 **Remove the display assembly bezel.**
 - 4 **Remove the four M3 x 3-mm screws that secure the display panel to the support bracket (see "12.1-Inch Display Assembly Bezel and Panel").**
 - 5 **Lift the bottom of the display panel out of the display-assembly top cover.**

- 6 Disconnect the bottom flex cable connector from the inverter connector by pulling straight up on the attached pull tab.
- 7 Remove the tape that covers the display panel connector.
- 8 Pull the top flex cable connector down and away to remove it from the display panel connector.

Display Assembly Latch

- ➔ NOTICE: Disconnect the computer and any attached devices from electrical outlets, and remove any installed batteries.
- ➔ NOTICE: To avoid ESD, ground yourself by using a wrist grounding strap or by touching an unpainted metal surface on the computer.

Display Assembly Latch for 14.1-Inch XGA Display Panels

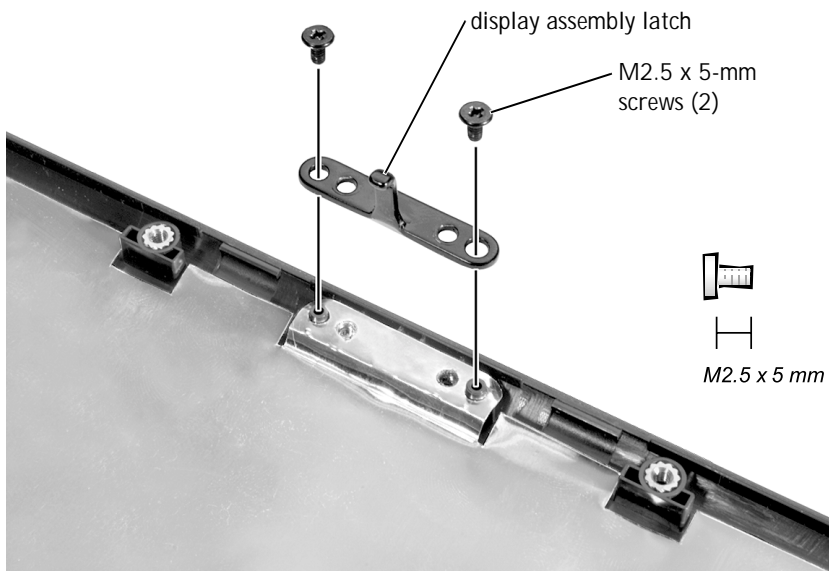

Removing the Display Assembly Latch

- 1 Remove the hard drive.
- 2 Remove the display assembly.
- 3 Remove the display assembly bezel.

- 4 Remove the display assembly latch by removing the two M2.5 x 5-mm screws that secure it to the display-assembly top cover.

Display Assembly Latch for 14.1-Inch SXGA+ and 12.1-Inch Display Panels

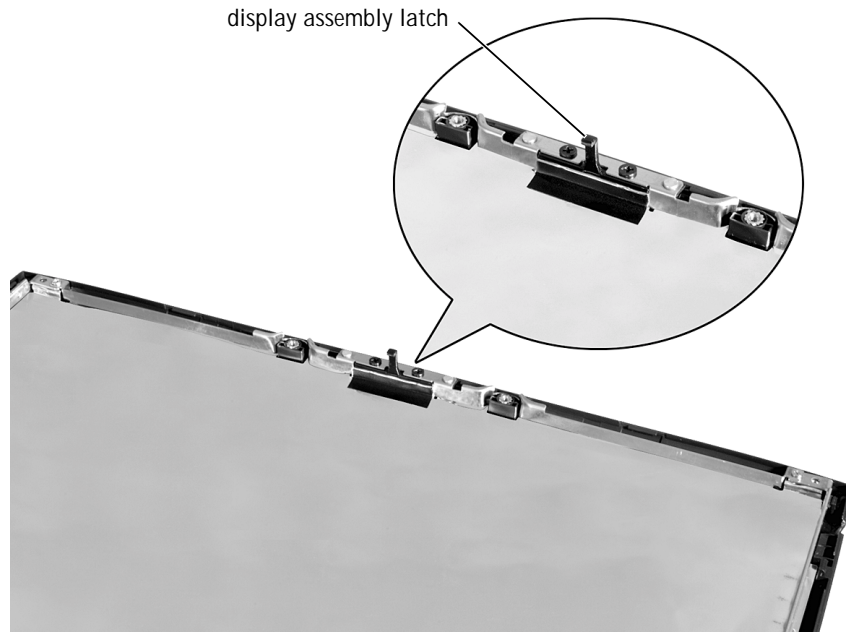

➡ NOTICE: Do not remove the display assembly latch from 14.1-inch SXGA+ and 12.1-inch display panels. If the latch is damaged, replace the display-assembly top cover.

Hinge Covers

Removing the Hinge Covers

Removing the Hinge Covers

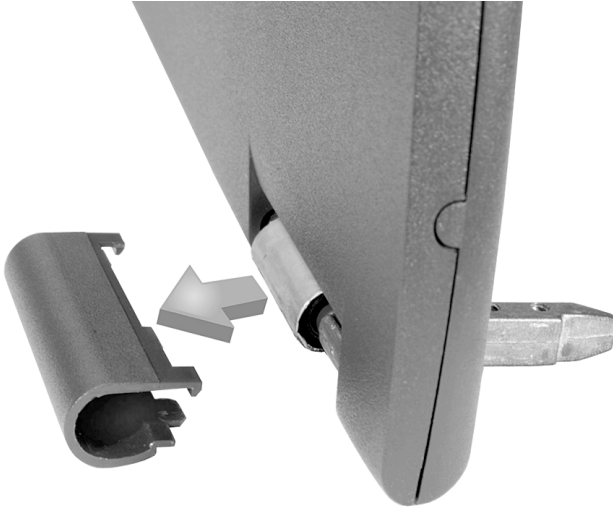

- 1 Remove the display assembly.
- 2 Rotate the hinges forward at an angle of approximately 90 degrees to the front of the display assembly.
- 3 To remove the hinge covers, slide them off of the hinges.

Replacing the Hinge Covers

Hinge Covers

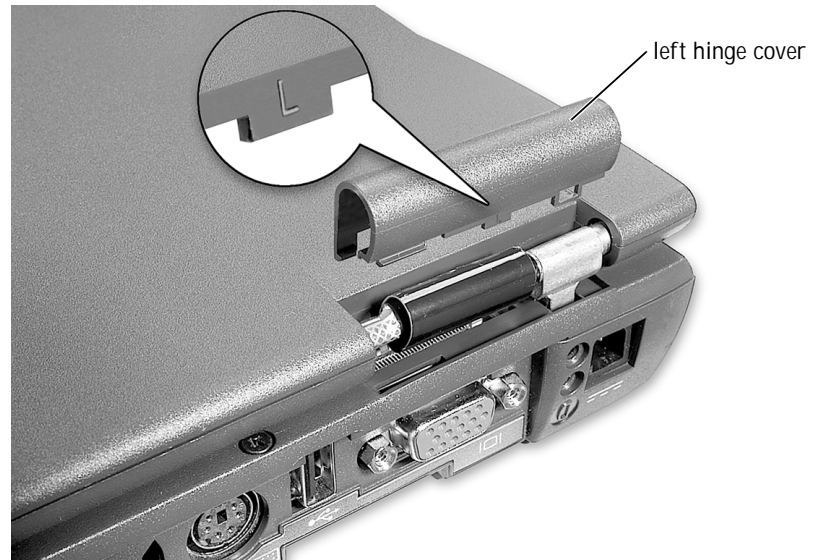
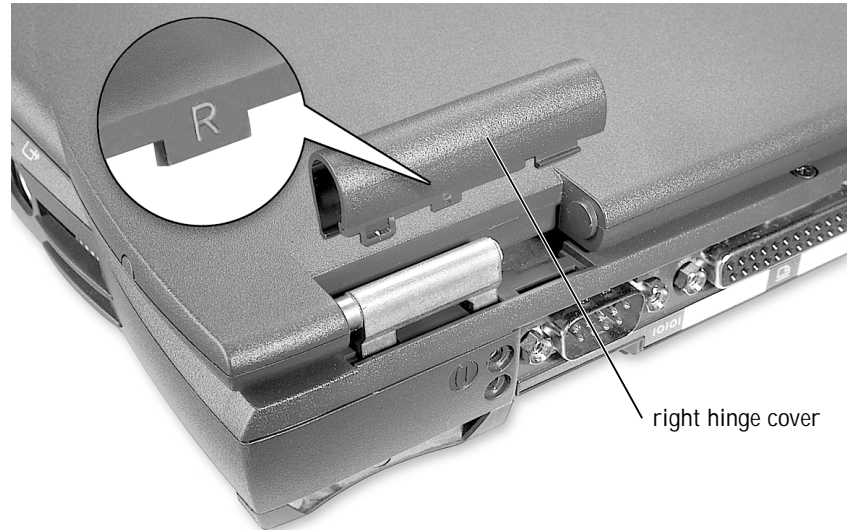

- 1 Attach the display assembly to the bottom case assembly.

- 2 Close the display assembly and snap the hinge covers in place over the hinges.



 **NOTE:** The right plastic hinge cover label includes an “R,” and the left plastic hinge cover label includes an “L.” The hinge cover labels face the back of the computer.

Palmrest Assembly

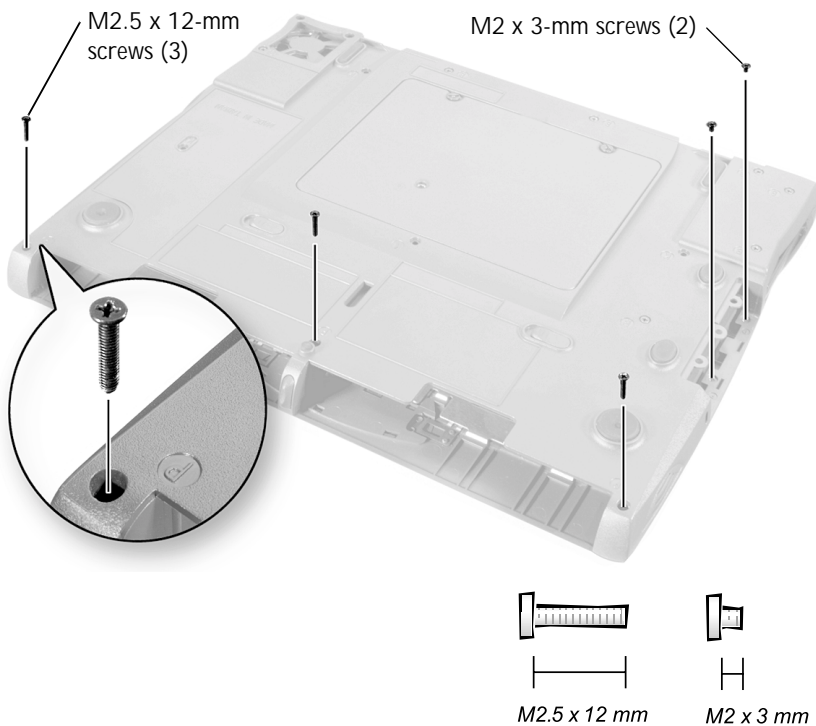
Removing the Palmrest Assembly Screws



Removing the Palmrest Assembly

-  **NOTICE:** Disconnect the computer and any attached devices from electrical outlets, and remove any installed batteries.
-  **NOTICE:** To avoid ESD, ground yourself by using a wrist grounding strap or by touching an unpainted metal surface on the computer.

➡ **NOTICE:** Read "Preparing to Work Inside the Computer" before performing the following procedure.

1 **Remove the hard drive.**

2 **Remove the keyboard.**

➡ **NOTICE:** You must remove the display assembly before you remove the palmrest assembly; the display assembly hinges pass through the back of the palmrest assembly.

3 **Remove the display hinge cover and display assembly.**

4 **Turn the computer over and remove the three M2.5 x 12-mm screws that are labeled with a "circle P."**

5 **Remove the two M2 x 3-mm screws that are located in the hard drive bay labeled with a "circle P."**

6 **Turn the computer over, and remove the three M2 x 3-mm screws that secure the palmrest to the bottom case assembly.**

- **Remove the two M2 x 3-mm screws that are located on the back edge of the bottom case assembly, underneath the display assembly.**
- **Remove the M2 x 3-mm screw located underneath the keyboard, on the right side of the bottom case assembly, next to the microprocessor thermal cooling assembly.**

7 **Pull up on the pull tab that is attached to the palmrest flex cable connector to remove it from the touch pad connector on the system board assembly.**

Palmrest Assembly

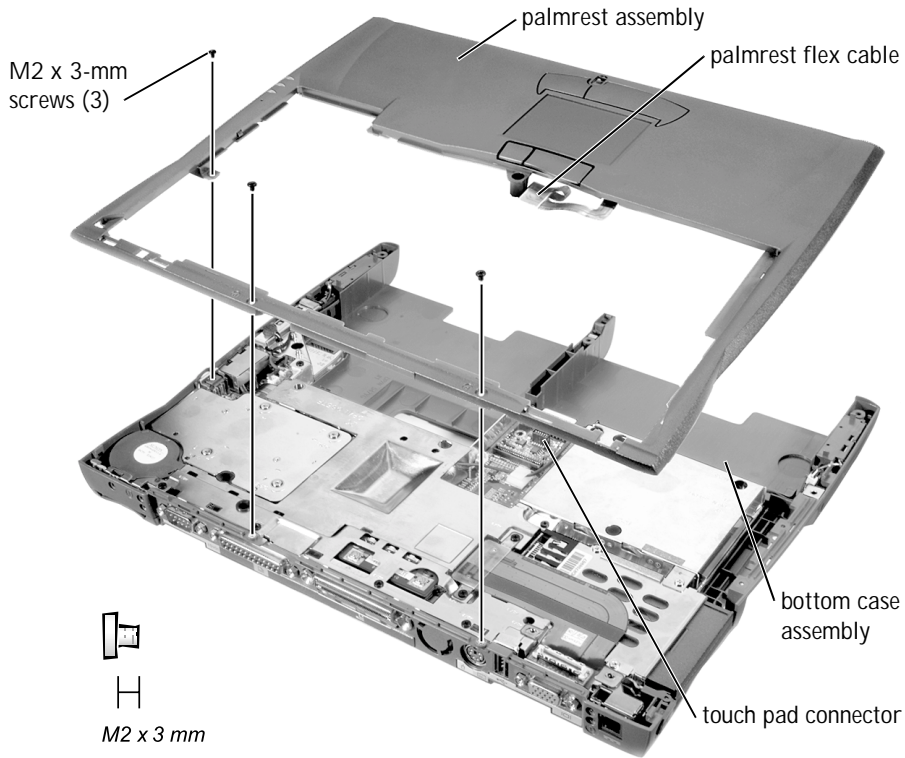

- 8 Using the plastic scribe along the edge of the plastic, remove the palmrest assembly from the bottom case assembly.

Microprocessor Thermal Cooling Assembly

Microprocessor Thermal Cooling Assembly

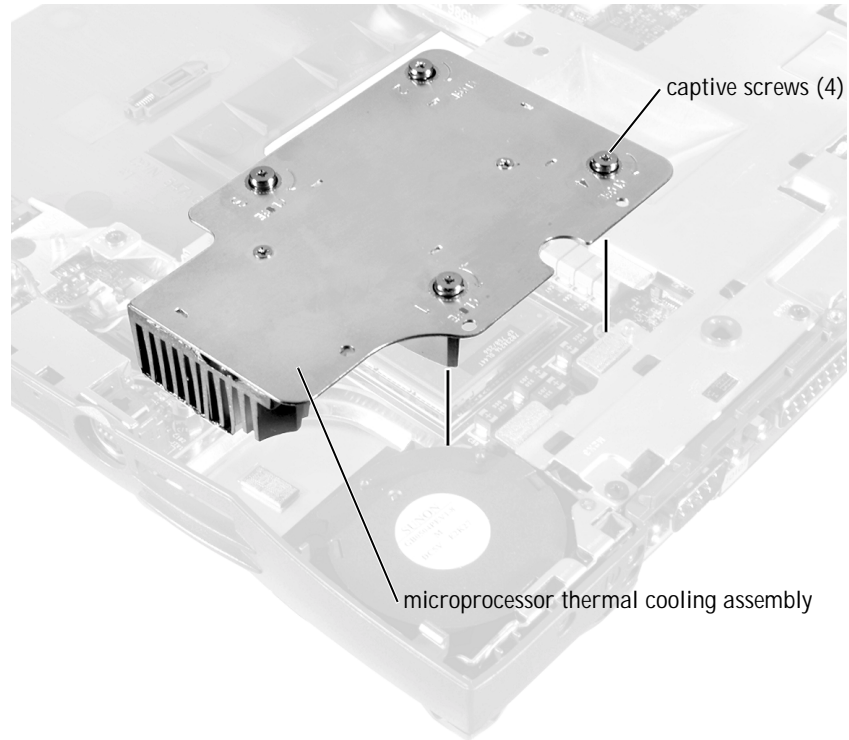

Removing the Microprocessor Thermal Cooling Assembly

- ➔ NOTICE: Disconnect the computer and any attached devices from electrical outlets, and remove any installed batteries.
- ➔ NOTICE: To avoid ESD, ground yourself by using a wrist grounding strap or by touching an unpainted metal surface on the computer.
- ➔ NOTICE: Read "Preparing to Work Inside the Computer" before performing the following procedure.

- 1 Remove the hard drive.
- 2 Remove the keyboard screws.

- 3 Turn the computer over, lift the keyboard up, rotate it forward toward the front of the computer, and place it face down on the palmrest.
- 4 Loosen the four captive screws securing the microprocessor thermal cooling assembly.
- 5 Remove the microprocessor thermal cooling assembly from the system board assembly.

➡ NOTICE: When reattaching the microprocessor thermal cooling assembly, tighten the captive screws in consecutive order, from 1 to 4.

Hybrid Cooling Fan

Hybrid Cooling Fan

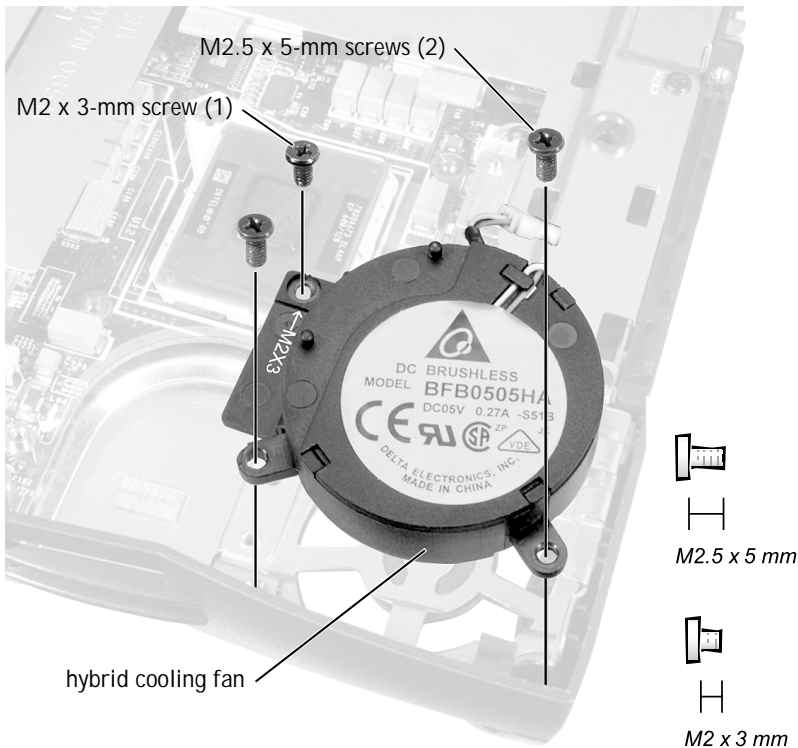

Removing the Hybrid Cooling Fan

- 1 Remove the hard drive.
- 2 Remove the keyboard assembly.
- 3 Remove the display assembly.
- 4 Remove the palmrest assembly.
- 5 Remove the thermal cooling assembly.
- 6 Remove the two M2.5 x 5-mm screws and one M2 x 3-mm screw that secure the hybrid cooling fan to the system board.
- 7 Disconnect the fan power cable from the system board interface connector and remove the hybrid cooling fan.



NOTE: The fan power cable is long, and can be pulled out from under the EMI shield to provide access to the connector.



NOTICE: Do not block the keyboard screw hole when reinserting the fan cable.

Microprocessor Module

Microprocessor Modules

- ➔ NOTICE: Hold the microprocessor down while turning the cam screw to prevent intermittent contact between the cam screw and microprocessor.

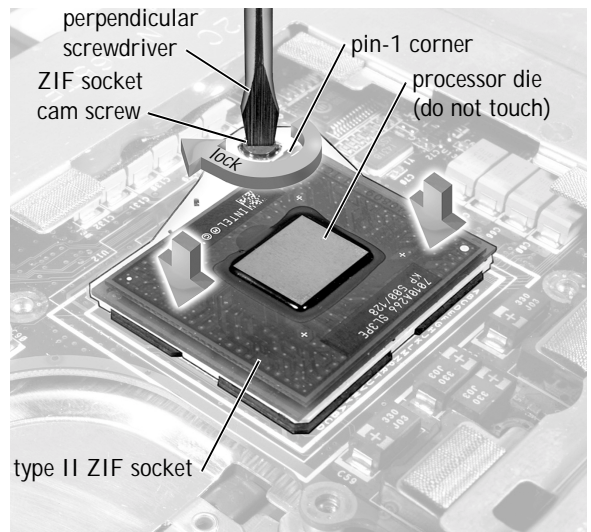
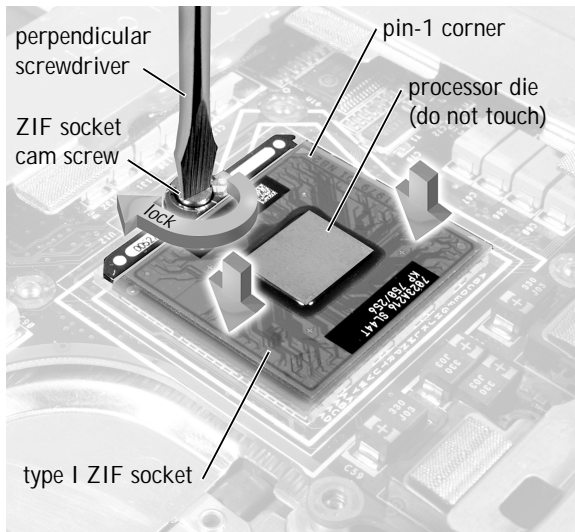

Removing the Microprocessor Module

- ➔ NOTICE: Disconnect the computer and any attached devices from electrical outlets, and remove any installed batteries.
 - ➔ NOTICE: To avoid ESD, ground yourself by using a wrist grounding strap or by touching an unpainted metal surface on the computer.
 - ➔ NOTICE: Read "Preparing to Work Inside the Computer" before performing the following procedure.
- 1 Remove the hard drive.
 - 2 Remove the keyboard assembly.
- ➔ NOTICE: To ensure maximum cooling for the microprocessor, do not touch the heat transfer areas on the thermal cooling assembly. The oils in your skin reduce the heat transfer capability of the thermal pads.

3 Remove the microprocessor thermal cooling assembly.

- ➡ NOTICE: When removing the microprocessor module, pull the module straight up. Be careful not to bend the pins on the microprocessor module.

4 Remove the microprocessor module.

- ➡ NOTICE: To avoid damage to the microprocessor, hold the screwdriver so that it is perpendicular to the microprocessor when removing the cam screw (see "Microprocessor Modules").

- a Use a small flat-head screwdriver and rotate the ZIF socket cam screw counter-clockwise 180 degrees to loosen the ZIF socket.

The ZIF socket cam screw secures the microprocessor assembly to the system board assembly. Take note of the arrow on the ZIF socket cam screw (see "Microprocessor Modules").

- ✍ NOTE: Your system has a type I or type II ZIF socket.

- b Use a microprocessor extraction tool to remove the microprocessor module.

Replacing the Microprocessor Module

- ➡ NOTICE: Seating the microprocessor module properly in the ZIF socket does not require force.

- ➡ NOTICE: A microprocessor module that is not properly seated can result in an intermittent connection, or permanent damage to the microprocessor and ZIF socket.

- 1 Align the pin-1 corner of the microprocessor module with the pin-1 corner of the microprocessor socket on the system board and insert the microprocessor module.

- ➡ NOTICE: You must position the microprocessor module correctly in the ZIF socket to avoid permanent damage to the module and the socket.

When the microprocessor module is correctly seated, all four corners are aligned to the same height. If one or more corners of the module are higher than the others, the module is not seated correctly.

- ➡ NOTICE: Hold the microprocessor down while turning the cam screw to prevent intermittent contact between the cam screw and microprocessor (see "Microprocessor Modules").

- 2 Tighten the ZIF socket by turning the cam screw clockwise to secure the microprocessor module to the system board assembly.



3 Update the BIOS using a flash BIOS update program diskette or CD.

 NOTE: For instructions to update or flash the BIOS, see the *Dell Portable Computer BIOS Update Guide*.

Reserve Battery

 NOTICE: The reserve battery provides power to the computer's RTC and NVRAM when the computer is turned off. Removing the battery causes the computer to lose the date and time information as well as all user-specified parameters in the BIOS. If possible, make a copy of this information before you remove the reserve battery.

Removing the Reserve Battery

-  NOTICE: Disconnect the computer and any attached devices from electrical outlets, and remove any installed batteries.
-  NOTICE: To avoid ESD, ground yourself by using a wrist grounding strap or by touching an unpainted metal surface on the computer.
-  NOTICE: Read "Preparing to Work Inside the Computer" before performing the following procedure.

Reserve Battery

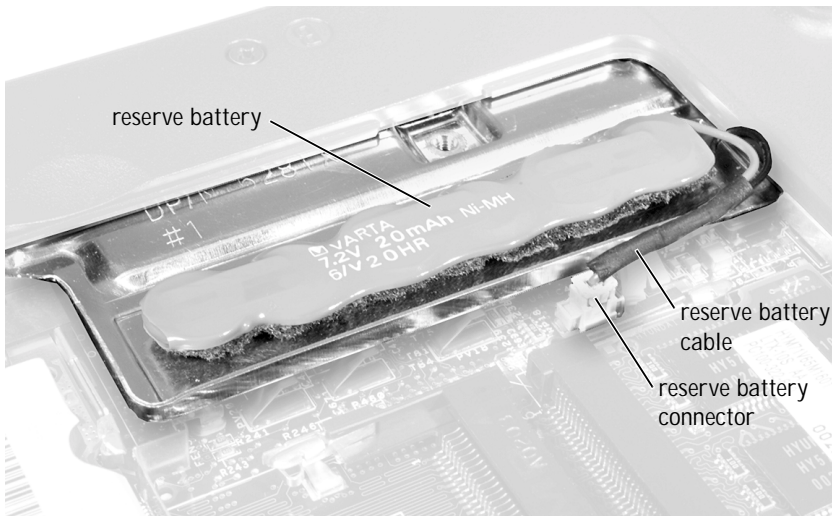

- 1 Remove the hard drive.
- 2 Remove the memory module cover.
- 3 Disconnect the reserve battery cable from the connector on the system board assembly located next to the reserve battery.
 NOTE: If the reserve battery is not located on the EMI shield as shown in "Reserve Battery," contact Dell technical support.
- 4 Remove the reserve battery from the EMI shield:
 - a Pry the reserve battery free from the foam pad.
 - b Remove the remnants of the foam pad from the EMI shield.

Replacing the Reserve Battery

- 1 Connect the reserve battery cable to the connector on the system board.
- 2 Position the reserve battery on the EMI shield next to the connector to minimize slack in the cable.
- 3 Update the BIOS using a flash BIOS update program diskette or CD.

 NOTE: For instructions to update or flash the BIOS, see the *Dell Portable Computer BIOS Update Guide*.

Speaker Assemblies

The speakers are located on the front left and right sides of the bottom case assembly. Each speaker assembly is marked with a right or left label. Take note of the speaker cable routing in the bottom case assembly so you can replace it correctly.

Routing the Left Speaker Cable

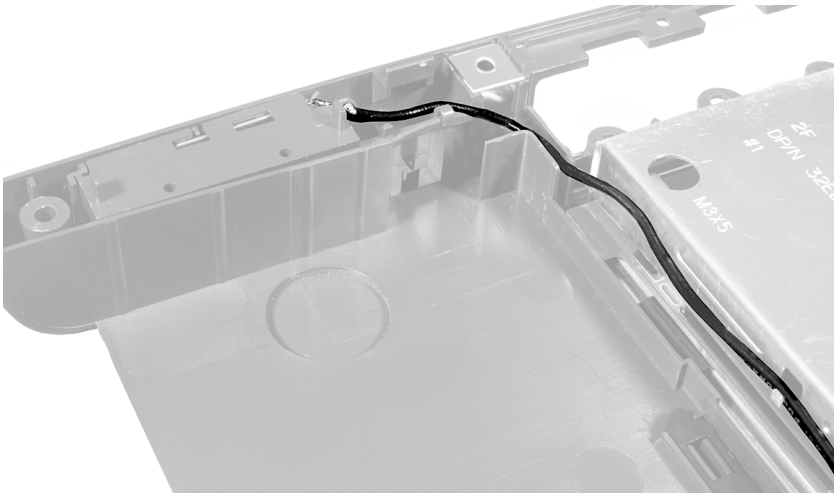



Removing the Speaker Assemblies

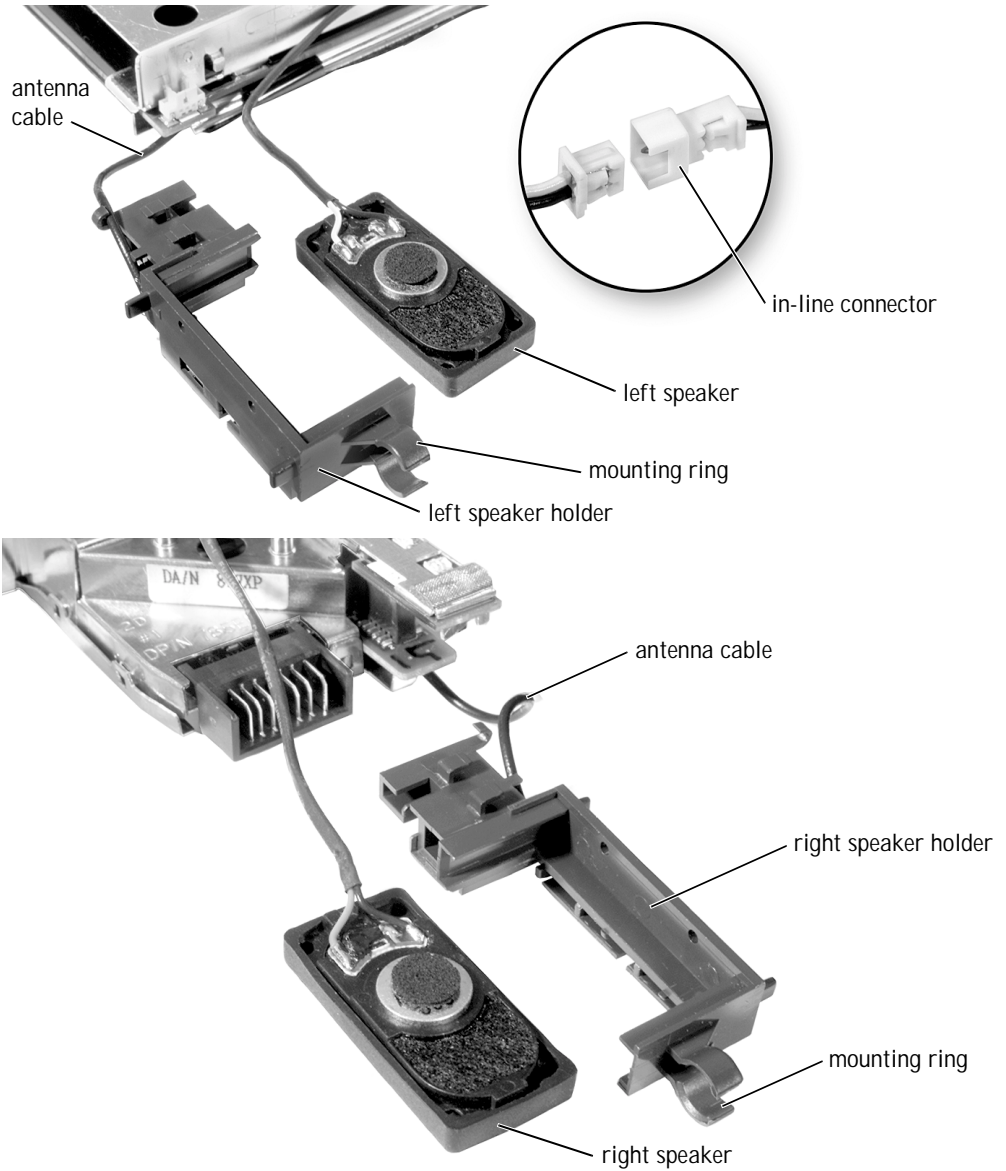

- ➔ NOTICE: Disconnect the computer and any attached devices from electrical outlets, and remove any installed batteries.
- ➔ NOTICE: To avoid ESD, ground yourself by touching an unpainted metal surface or by using a wrist grounding strap.
- ➔ NOTICE: Read "Preparing to Work Inside the Computer" before performing the following procedure.
- ➔ NOTICE: Make note of the speaker and antenna wire routing so you can replace them properly under their routing clips.

Speaker Assemblies



- 1 Remove the hard drive.
 - 2 Remove the keyboard assembly.
 - 3 Remove the display assembly.
 - 4 Remove the palmrest assembly.
 - 5 Disconnect the speaker interface cable connectors.
-  NOTICE: Do not pull the antenna cable when removing the speaker (see “Speaker Assemblies”).
- 6 Remove the speaker assemblies by pulling them straight up and out of the bottom case assembly
-  NOTICE: Handle the speaker assemblies and speakers with care to avoid damaging the speaker cones.
-  NOTE: The left speaker has an in-line connector, and its cable is longer than the right speaker.

Replacing the Speaker Assembly

- 1 To replace the speaker assembly, place the mounting ring over the front palmrest screw post.
-  NOTICE: Make sure the speaker wires are under their routing clips. Route the left speaker wire properly between the battery bay and hard drive area.
- 2 Slide the speaker assembly down in to the bottom case assembly.
-  NOTE: Speakers face out in the bottom case assembly holders.

System Board Assembly

The system board’s BIOS chip contains the system’s service tag number, which is also visible on a bar-code label on the bottom of the computer. The replacement kit for the system board assembly includes a CD that provides a utility for transferring the service tag number to the replacement system board assembly.

Removing the System Board Assembly Screws

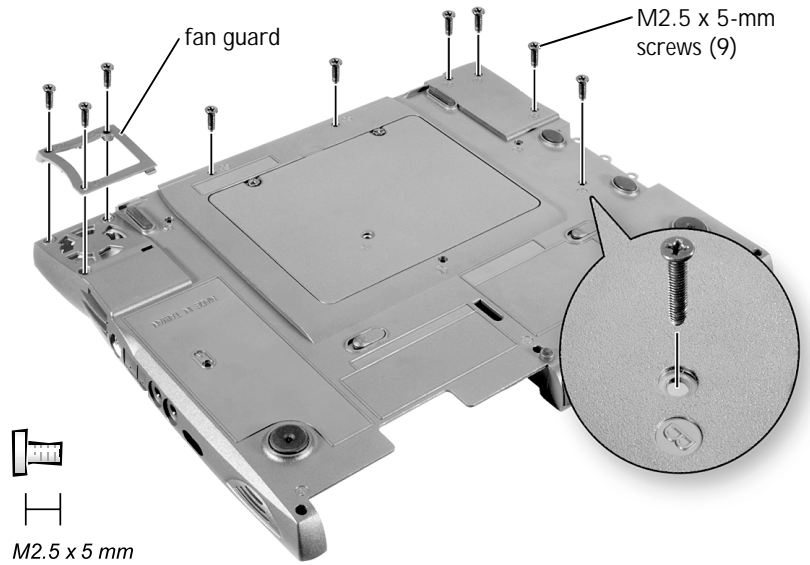

Removing the System Board

- ➔ **NOTICE:** Disconnect the computer and any attached devices from electrical outlets, and remove any installed batteries.
- ➔ **NOTICE:** To avoid ESD, ground yourself by using a wrist grounding strap or by periodically touching an unpainted metal on the computer.
- ➔ **NOTICE:** Read "Preparing to Work Inside the Computer" before performing the following procedure.

- 1 Remove the hard drive.
- 2 Remove the keyboard assembly.
- 3 Remove the display assembly.
- 4 Remove the palmrest assembly.
- 5 Remove the thermal cooling assembly.
- 6 Remove the microprocessor.
- 7 Verify that all PC Cards or plastic blanks are removed from the PC Card slot.

- 8 Verify that the PC Card ejectors do not extend from the PC Card slot.
- 9 Turn the computer over, and remove the six M2.5 x 5-mm screws labeled with a "circle B" that secure the system board assembly to the bottom case assembly.
- 10 Remove the three M2.5 x 5-mm screws labeled with a "circle B" that secure the fan guard to the bottom case assembly. The fan guard is located on the right of the bottom case assembly.

System Board Assembly

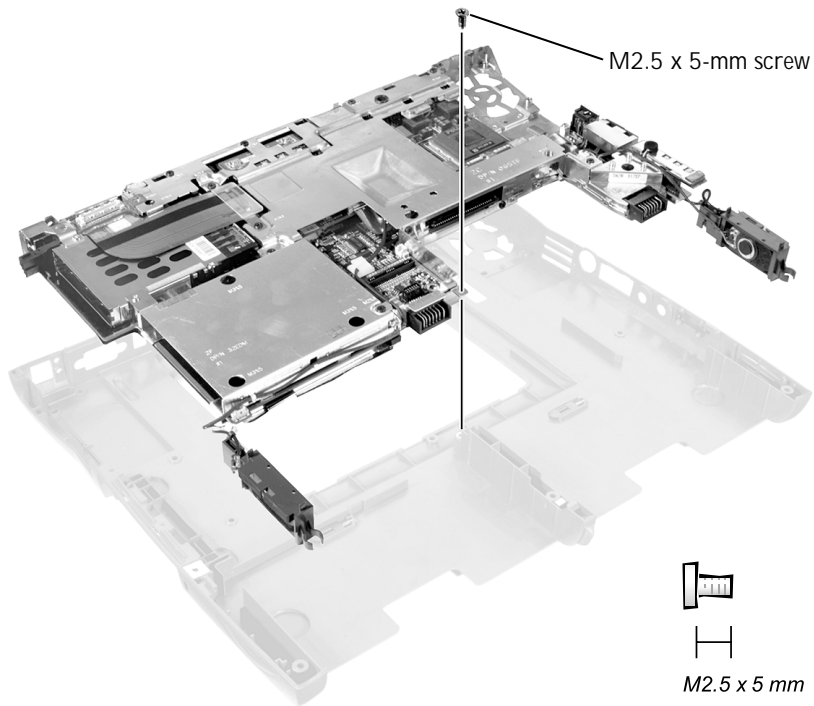

- 11 Turn the bottom case assembly over and remove the M2.5 x 5-mm screw, which is identified by a white "circle B" and arrow on a red label attached to the top of the battery connector on the front center of the system board.
- 12 Remove the speakers from the bottom case assembly.

- 13 Pull the right side of bottom case assembly, next to the external headphone and microphone connectors, away from the system board assembly as you simultaneously lift the front of the system board assembly out and away from the bottom case assembly.

Replacing the System Board

- 1 Install the microprocessor on the replacement system board.
- 2 Connect the right and left speaker to the replacement system board.
- 3 Install the replacement system board.
 - a Insert the external microphone and headphone connectors through the plastic bottom case assembly.
 - b Replace the nine M2.5 x 5-mm screws, starting on the right side of the bottom case assembly.
 - c Replace the fan guard cover, inserting the tab into the bottom case assembly and replace the three M2.5 x 5-mm screws (see “Removing the System Board Assembly Screws”). If you replace the screw opposite the tab first, it makes it easier to insert and replace the other two screws.
- 4 Replace the memory modules, mini-PCI card, speaker assemblies, and the thermal cooling assembly removed from the old system board.
- 5 Replace the palmrest assembly, the display assembly, the keyboard assembly, and the hard drive.
- 6 Replace the modular bay devices and any PC Cards or plastic blanks in the PC Card slot.
- 7 Insert the diskette or CD that accompanied the replacement system board assembly into the appropriate drive, and turn on the computer. Follow the instructions on the screen.



NOTE: Be sure to route cables so that they will not be crimped or pinched when the complete assembly is put back together.



NOTE: After replacing the system board assembly, be sure to enter the system's service tag number into the BIOS of the replacement system board assembly.

Battery and Modular Bay Latch Assemblies

Battery and Modular Bay Latch Assemblies

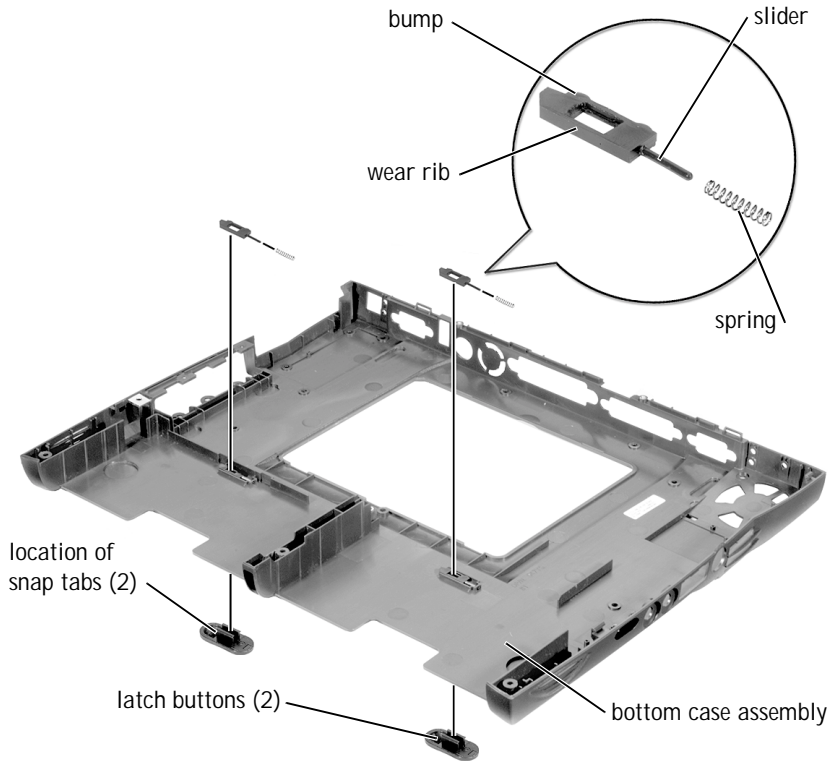

Removing the Battery and Modular Bay Latch Assemblies

- ➔ NOTICE: Disconnect the computer and any attached devices from electrical outlets, and remove any installed batteries.
- ➔ NOTICE: To avoid ESD, ground yourself by using a wrist grounding strap or by touching an unpainted metal surface on the computer.

 **NOTICE:** Read "Preparing to Work Inside the Computer" before performing the following procedure.

- 1 Remove the hard drive.
- 2 Remove the keyboard assembly.
- 3 Remove the display assembly.
- 4 Remove the palmrest assembly.
- 5 Remove the system board.
- 6 Remove the battery latch button from the bottom case assembly by squeezing the snap tabs.

Apply pressure to the latch and spring while unsnapping the snap tabs to prevent the latch assembly from coming loose from the case. If the latch assembly does come loose from the case:

- a Reinsert the spring onto the slider on the latch, and reinstall the module latch into the holding features on the inside of the case.
- b Ensure that the slider is inserted in its respective hole, that the side of the latch with the two bumps is facing the back of the case, and that the surface with the wear ribs is facing the bottom of the case.



NOTE: The latch will not function properly if the slider is oriented incorrectly.

- 7 Snap in the new latch button from the bottom of the base, making certain the snap tabs are fully engaged in the latch.
- 8 Ensure that the newly installed latch moves smoothly and freely when pushed and released.
- 9 Repeat steps 5 through 7 for the modular bay latch.

Index

B

battery and modular bay latch assemblies
removing, 57

D

display assembly
removing, 26

display assembly bezel
removing, 29, 33

display assembly bezel (12.1-inch)
removing, 34

display assembly bezel (14.1-inch)
removing, 30

display assembly latch
removing, 37, 38

display panel (12.1-inch)
removing, 34
replacing, 35

display panel (14.1-inch)
removing, 30
replacing, 31

display-assembly top cover
replacing, 35

display-feed flex cable

removing from 12.1-inch display panel, 36

removing from 14.1-inch display panel, 32

H

hard drive, 17
removing, 17
replacing, 17

hinge covers
removing, 39
replacing, 40

hybrid cooling fan
removing, 46

K

keyboard, 23
removing, 23
replacing, 25

M

memory module, 18
removing, 19
replacing, 20

microprocessor module
removing, 47

replacing, 48

microprocessor thermal cooling assembly
removing, 44

mini-PCI card, 20
removing, 22
replacing, 22

P

palmrest assembly
removing, 41

preparing to work inside the computer, 10

R

recommended tools, 11

reserve battery
removing, 49
replacing, 50

S

screw identification and tightening, 12

speaker assemblies
removing, 51
replacing, 53

system board

- removing, 54

- replacing, 56

system board assembly

- removing, 47

system components, 16

T

thermal cooling assembly

- removing, 44



082EWX A01

P/N 82EWX Rev. A01



Printed in the U.S.A.



www.dell.com
support.dell.com

